

Glossary of Terminology Used in Bolt Torquing

ACORN NUT

A nut (so-called because of its shape) that has a domed top so that it prevents contact with the external thread.



AEROTIGHT NUT

A torque prevailing nut of all metal construction. The nut is slotted in two places which, after the nut has been tapped, are bent slightly inwards and downwards. When the nut is screwed onto the bolt thread the two slotted parts are forced back to their original position. Their stiffness causes the nut threads to bind onto the bolt threads and thus provides a prevailing torque. Aerotight is a registered trade mark of The Premier Screw and Repitition Co. Ltd of Woodgate, Leicester, United Kingdom, LE3 5GJ.

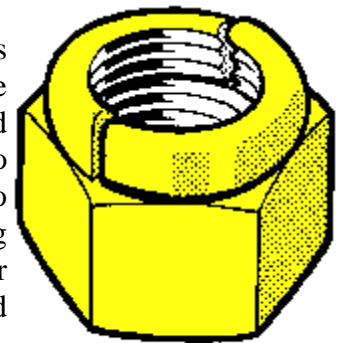

Aerotight Nut

ANTI-FRICTION COATING

AF coatings are dry lubricants consisting of suspensions of solid lubricants, such as graphite, PTFE or molybdenum disulphide of small particle size in a binder. Such coatings can be applied to fastener threads to replace metallic coatings such as zinc and cadmium and offer maintenance free permanent lubrication. By careful selection of the lubricants, AF coatings can be designed to meet specific applications. The coatings are permanently bonded to the metal surface and provide a lubricating film preventing direct metal to metal contact.

ANTI-SEIZE COMPOUND

An anti-seize compound is used on the threads of fasteners in some applications. The purpose of the compound depends upon the application. It can prevent galling of mating surfaces - such compounds are frequently used with stainless steel fasteners to prevent this effect from occurring. In some applications it is used to improve corrosion resistance to allow the parts to be subsequently dis-assembled. Thirdly, it can provide a barrier to water penetration since the threads are sealed by use of the compound.

AUTOLOK NUT

A torque prevailing nut of an all metal construction. Covered by UK patent 1180842 the nut is marketed by GKN Screws and Fasteners Limited.

ALLOWANCE

An intentional clearance between internal or external thread and the design form of the thread when the thread form is on its maximum metal condition. Not all classes of fit have an allowance. For metric threads the allowance is called the fundamental deviation.

ANAEROBIC ADHESIVE

An adhesive which hardens in the absence of air, such adhesives are often used as a thread locking medium.

ANGLE CONTROLLED TIGHTENING

A tightening procedure in which a fastener is first tightened by a pre-selected torque (called the snug torque) so that the clamped surfaces are pulled together, and then is further tightened by giving the nut an additional measured rotation. Frequently bolts are tightened beyond their yield point by this method in order to ensure that a precise preload is achieved. Bolts of short length can be elongated too much by this method and the bolt material must be sufficiently ductile to cater for the plastic deformation involved. Because of the bolt being tightened beyond yield, its re-use is limited.

BASIC THREAD PROFILE

This is the theoretical profile of external and internal threads with no manufacturing tolerance applied.

BEARING STRESS

The surface pressure acting on a joint face directly as a result of the force applied by a fastener.

BIHEXAGON HEAD

A bolt or screw whose cross section of its head is in the shape of a 12 pointed star.

BLACK BOLTS AND NUTS

The word black refers to the comparatively wider tolerances employed and not necessarily to the colour of the surface finish of the fastener.

BOLT

A bolt is the term used for a threaded fastener, with a head, designed to be used in conjunction with a nut.

BREAKAWAY TORQUE

The torque necessary to put into reverse rotation a bolt that has not been tightened.

BREAKLOOSE TORQUE

The torque required to effect reverse rotation when a pre-stressed threaded assembly is loosened.

BRITISH STANDARD BRASS

A specialist thread form based upon the Whitworth thread and consisting of 26 threads per inch whatever the thread diameter.

BSF

British Standard Fine. A thread form based upon the British Standard Whitworth form but with a finer thread (more threads per inch for a given diameter). This thread form was first introduced in 1908, the thread form is specified in BS 84: 1956.

BSW

British Standard Whitworth. A thread form developed by Sir Joseph Whitworth in 1841. The thread form has rounded roots and crests, the thread form is specified in BS 84: 1956. This thread form was superceded by the Unified thread in 1948 and then the metric thread form.

BUMP THREAD

A modified thread profile patented and trade mark of the Bosco Tool Inc. The thread form has a small projection at the pitch diameter that eliminates the clearance from the thread assembly on both flanks. By doing this it is claimed that resistance to vibration loosening is significantly improved.

CADMIUM ELECTROPLATING

Coating of threaded fasteners with cadmium can provide the parts with excellent corrosion resistance. The appearance of the coating is bright silver or yellow if subsequently passivated. The friction values associated with this coating are also comparatively low. A chromate conversion coating is frequently applied to the surface to improve corrosion resistance. Cadmium is not now frequently used because of the environmental and worker health problems associated with the coating process and should not be used in applications above 250C or when contact with food is possible.

CLAMPING FORCE

The compressive force which a fastener exerts on the joint.

CLASS OF FIT

The Class of Fit is a measure of the degree of fit between mating internal and external threads. Three main Classes of Fit are defined for metric screw threads :

FINE: This has a tolerance class of 5H for internal threads and 4h for external threads.

MEDIUM: This has a tolerance class of 6H for internal threads and 6g for external threads.

COARSE: This has a tolerance class of 7H for internal threads and 8g for external threads.

For Unified threads, a similar designation as for metric threads is used. The thread classes used are 1A, 2A and 3A for external threads and 1B, 2B and 3B for internal threads.

CLEVELOC NUT

A torque prevailing nut of all metal construction. The collar of the nut is elliptical in cross section and it is this that provides the flexible locking element. The nut is pre-lubricated to reduce the tightening torque. Cleveloc is a registered trade name of Forest Fasteners.

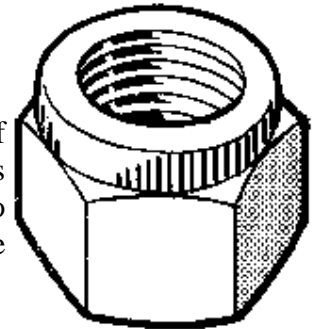

Cleveloc Nut

COEFFICIENT OF FRICTION

A dimensionless number representing the ratio of the friction force to normal force. Typically for threaded connections it is between 0.10 to 0.18 but can vary significantly depending upon the materials used and whether a lubricant has been used.

COMMINGLING

A term used to describe the undesirable practice of mixing fasteners from different batches that are the same size and grade in the same container.

CONE PROOF LOAD

This is an axial applied force applied to a nut when it is seated on a cone shaped washer which has an included angle of 120 degrees. Failure in this test is usually due to the nut splitting. The intention of the test is to introduce a nut dilation operation which will assess the potential detrimental effects of surface discontinuities. This type of test is sometimes applied to nuts which are intended for high temperature service.

DECOMPRESSION POINT

The point at which there is zero pressure at the joint interface as a result of forces applied to the joint. If the applied force is increased beyond the decompression point, a gap will form at the interface. Analytically, a criteria of joint failure is often taken as when the applied force on the joint reaches the decompression point. This is because forces acting on the bolt(s) can dramatically increase at this

point. Loading beyond this point can also result in fretting at the interface that will lead to bolt tension loss that will subsequently lower the decompression point. This process can continue until bolt failure does occur. The failure can be by fatigue or other mechanism but the underlying cause was loading of the joint beyond the decompression point. It is for this reason that it is frequently taken as a failure criteria in analysis work.

DACROMET

A high performance surface coating that can be applied to fasteners. The coating consists of passivated zinc flakes that are stoved onto the metal surface. The coating can be coloured and eliminates the risk of hydrogen embrittlement associated with electroplated metal. DACROMET is a registered trademark of Metal Coatings International, Inc. of Chardon Ohio

DESIGN FORM OF THREAD

The design form of an internal or external thread is the thread form in it's maximum metal condition. It is the same as the basic thread profile except that the thread roots are rounded. If either the internal or external thread form exceeds the design form of the thread profile then a potential interference exists.

DIRECT TENSION INDICATORS

Direct Tension Indicators (DTI's) is a term sometimes used to describe load indicating washers. Projections on the face of the washer (usually on the face abutting the bolt head or nut) that deform under loading as the bolt is tensioned. An indication of the tension in the bolt can be made by measuring the gap between the washer face and the nut or bolt head. The smaller the gap - the greater the tension in the bolt. Commonly used in civil rather than mechanical engineering applications.

DYNAMIC FRICTION

Resistance to relative movement of two bodies that are already in motion.

EFFECTIVE DIAMETER

This is the diameter of an imaginary cylinder coaxial with the thread, which has equal metal and space widths. It is often referred to as pitch diameter. Sometimes referred to as the simple effective diameter to differentiate from the virtual effective diameter.

EFFECTIVE NUT DIAMETER

Twice the effective nut radius.

EFFECTIVE NUT RADIUS

The radius from the centre of the nut to the point where the contact forces, generated when the nut is turned, can be considered to act.

ELECTROLESS NICKEL

A relatively thin, hard coating that can be applied to threads and deposited uniformly. Bright metallic in appearance this coating has excellent resistance to wear and corrosion.

EMBEDMENT

Localized plastic deformation which occurs in the vicinity of clamped fasteners or in the fastener threads.

ENVIRONMENTALLY ASSISTED CRACKING (EAC)

A process that can occur with the use of high strength steel fasteners in which crack initiation and growth occurs in the fastener at a comparatively low stress level as a result of interactions that occur with the environment. Hydrogen is suspected of causing EAC in high strength steel fasteners, the hydrogen being produced as a result of chemical reactions (galvanic corrosion in a moist environment) or being present from a plating process that may have been applied to the fastener.

EXTERNAL FORCE OR LOAD

Forces exerted on a fastener as a result of an applied loading to the joint.

EXTERNAL THREAD

A screw thread which is formed on an external cylinder, such as on bolts, screws, studs etc.

FLOATING TYPE FLANGE JOINT

A conventional flanged joint in which a gasket is compressed by bolts - the gasket is not rigidly located. Calculation methods such as the ASME code in the USA and the EN1591 code in Europe.

FLUORO-CARBON THREAD COATING

A low friction coating applied to threads. This type of coating is frequently used to prevent thread fouling when an assembly containing threaded fasteners is painted. Unless masked in some way before painting, electro deposited primers can cover the threads. If this occurs assembly difficulties can result unless the expensive chore of cleaning the threads is completed. A fluoro-carbon thread coating eliminates the need for masking or cleaning since paint will not adhere to the coating. This type of coating can also prevent problems caused by weld splatter obstructing the threads of weld nuts during their placement. Such coatings also have the property of reducing the torque-tension scatter during tightening.

FRICTION

Mechanical resistance to the relative movement of two surfaces. There are two main types of friction; **STATIC FRICTION** and **DYNAMIC FRICTION**. Typically static friction is greater than dynamic friction.

FRICTION STABILIZERS

Coating materials used on fasteners with the intention of reducing the scatter in the thread and bearing surface friction coefficients.

FUNDAMENTAL DEVIATION

An intentional clearance between internal or external thread and the design form of the thread when the thread form is on its maximum metal condition. For metric threads the fundamental deviation are designated by letters, capitals for internal threads and small letters for external threads. Some tolerance classes have a fundamental deviation of zero. For imperial threads the fundamental deviation is called the allowance.

FUNDAMENTAL TRIANGLE HEIGHT

The fundamental triangle height is normally designated with the letter H. This is the height of the thread when the profile is extended to a sharp vee form. For 60 degree thread forms such as metric and Unified thread series, H equals 0.866025 times the thread pitch.

GALLING

A severe form of adhesive wear which occurs during sliding contact of one surface relative to another. Clumps of one part stick to the mating part and break away from the surface. (Can frequently occur when both the nut and bolt are zinc coated.)

GRIP LENGTH

Total distance between the underside of the nut to the bearing face of the bolt head; includes washer, gasket thickness etc.

HARD JOINT

A joint in which the plates and material between the nut and bolt bearing surfaces have a high stiffness when subjected to compression by the bolt load. A joint is usually defined as hard if the bolt is tightened to its full torque and it rotates through an angle of 30 degrees or less after it has been tightened to its snug condition.

HARDENED WASHERS

The force under the head of a bolt or nut can exceed, at high preloads, the compressive yield strength of the clamped material. If this occurs excessive embedding and deformation can result in bolt preload loss. To overcome this hardened washers under the bolt head can be used to distribute the force over a wider area into the clamped material. A more modern alternative is to use a flange headed nuts and bolts.

HEAT TIGHTENING

Heat tightening utilises the thermal expansion characteristics of the bolt. The bolt is heated and expands: the nut is indexed (using the angle of turn method) and the system allowed to cool. As the bolt attempts to contract it is constrained longitudinally by the clamped material and a preload results. Methods of heating include direct flame, sheathed heating coil and carbon resistance elements. The process is slow, especially if the strain in the bolt is to be measured, since the system must return to ambient temperature for each measurement. This is not a widely used method and is generally used only on very large bolts.

HIGH STRENGTH FRICTION GRIP BOLTS

Sometimes abbreviated to HSFG bolts. Bolts which are of high tensile strength used in conjunction with high strength nuts and hardened steel washers in structural steelwork. The bolts are tightened to a specified minimum shank tension so that transverse loads are transferred across the joint by friction between the plates rather than by shear across the bolt shank.

HOLD AND DRIVE BOLTS

Special bolts that have a tang at the threaded end of the shank. This tang is gripped by the tightening tool during assembly so that the reaction torque is absorbed whilst the nut is tightened from the same side. Such bolts allow what used to have to be done by two men to become a one-man task.

HOT BOLTING

This term is used for the completion of maintenance work on a bolted joint when the joint is under loading. This can involve the replacement of individual bolts. There are risks both to the joint itself and to health and safety associated with this technique.

HYDRAULIC TENSIONER

A hydraulic tool used to tighten a fastener by stretching it rather than applying a large torque to the nut. After the fastener has been stretched, the nut is run down the thread to snug up with the joint, the hydraulically applied load is then removed resulting in tension being induced into the fastener.

HYDROGEN EMBRITTLEMENT

Steel fasteners exposed to hydrogen can fail prematurely at a stress level well below the materials yield strength. Hydrogen embrittlement occurs in fasteners usually as a result of the part being exposed to hydrogen at some time during its manufacturing process but it can also occur through in-service corrosion. Electroplating is generally considered to be a major cause of hydrogen absorption in steel fasteners due to the release of hydrogen during this process. Higher strength steels are more susceptible to hydrogen embrittlement than lower strength steels, however it is considered that there is no lower strength limit. As a rule of thumb, steels below Rockwell C 35 are considered to be far less

susceptible. Tests such as the incremental load hydrogen embrittlement test can be completed to assess if hydrogen embrittlement is present in a batch of fasteners.

IMPACT WRENCH

A wrench, usually powered by electricity or air, in which repeated blows from little hammers are used to generate torque to tighten fasteners. The torque applied to the fastener depends upon the time and the air pressure applied to the tool (for pneumatic wrenches). The torque applied by an impact wrench to a fastener is influenced by the joint stiffness.

INSTANTANEOUS CENTRE OF ROTATION

The point in space that an eccentrically shear loaded joint rotates about. The deformation and the load sustained by an individual bolt in a bolt group is dependent upon the distance that the bolt is from the instantaneous centre. The direction that the individual bolt force acts is perpendicular to a line joining that bolt to the instantaneous centre.

INTEGRAL FASTENER

A term used to describe types of fasteners which are highly resistant to vibration loosening and/or removal. Some types have special thread forms.

INTERNAL THREAD

A screw thread which is formed in holes, such as in nuts.

JAM NUTS

See [LOCKNUT](#)

JOINT CONTROL TIGHTENING

See [YIELD CONTROLLED TIGHTENING](#)

K FACTOR

The factor in the torque tightening equation: $T=KDF$ where T is the fastener tightening torque in Newton metres, D is the fastener diameter in metres, F is the fasteners preload in Newtons and K is a factor whose value is often taken as 0.2. The formula gives the approximate tightening torque for standard fasteners used under normal conditions.

KEPS

A pre-assembled nut and washer assembly (the washer is attached to the nut so that it won't fall off)- a trademark of ITW Shakeproof. The origin of the word came from Sha**KEP**proof. The s on the end being acquired due to them being purchased in quantities usually greater than one.

LEFTHAND THREAD

A screw thread that is screwed in by rotating counterclockwise.

LENGTH OF ENGAGEMENT

The axial distance over which an external thread is in contact with an internal thread.

LOCK NUT

There are two common usage's of this term:

1. A nut which provides extra resistance to vibration loosening by either providing some form of prevailing torque, or, in free spinning nuts, by deforming and/or biting into mating parts when fully tightened.
2. The term is sometimes used for thin (or jam) nuts used to lock a thicker nut. When used in this way the thin nut should be adjacent to the joint surface and tightened against the thick nut. If placed on top of the thick nut the thin nut would sustain loads it was not designed to sustain.

MAJOR DIAMETER

This is the diameter of an imaginary cylinder parallel with the crests of the thread; in other words it is the distance from crest to crest for an external thread, or root to root for an internal thread.

MEANSHIFT

The difference in tightening torque values produced by the same tightening tool on hard and soft joints. A hard joint typically gives a higher torque value than a soft joint. Generally speaking, the lower the meanshift of a tightening tool, the better it will be in achieving a specified torque value irrespective of the joint condition.

METAL TO METAL CONTACT FLANGE JOINT

A flanged joint in which a gasket is compressed by bolts - the gasket being located in a recess within the joint so that it is compressed by the bolt loads until metal to metal contact occurs. Unlike the FLOATING TYPE FLANGE JOINT, for metal to metal type joints there are no standardised gasket factor definitions, test procedures, nor generally acknowledged calculation procedures available.

MINOR DIAMETER

This is the diameter of an imaginary cylinder which just touches the roots of an external thread, or the crests of an internal thread.

MODEL ENGINEERS THREAD (M.E.)

A thread based upon the Whitworth thread form that was established in 1912. A very fine thread (a 3/32 inch thread having 60 tpi for example).

MOLYBDENUM DISULPHIDE

A solid lubricant that acts as a high pressure resistant film. Can be used by itself as a dry lubricant as well as in with other solid lubricants and in oils and greases. Used in threads, such lubricants act as a separating film to prevent corrosion formation on the thread surface (even under adverse temperature and environmental conditions) ensuring the release of the threaded connection. Such films can also act as friction stabilisers.

NICKED THREADS

Nicks or indentations in threads can occur during the manufacturing process and during fastener transportation. In general, nicked thread problems tend to increase as the thread diameter increases and for fine pitches. There are acceptance tests for nicked threads that involve measuring the maximum torque required to drive a GO gauge down the thread. Examples of acceptance tests are SAE J123 and the Ford Motor specification WA990 1993. Nicks and indentations in threads are sometimes referred to as gouges.

NOMINAL DIAMETER

The diameter equal to the external diameter of the threads.

NUT DILATION

Under load, the wedging action of the threads causes dilation of the nut resulting in an increase in the minor diameter of the nut, and reducing the effective shear areas of both the external and internal threads.

NUT RUNNER

A torque control fastener tightening tool that is usually powered by compressed air. The design of the tool is such that attempts are made to ensure that the applied torque is independent of joint stiffness.

NYLOC NUT

A torque prevailing nut that uses a nylon patented insert to provide a locking feature. The nylon insert, it is claimed, helps to seal the bolt thread against seepage of water, oil, petrol, paraffin and other liquids. The nut is covered by UK patent 8028437 and European patent 81303450-1. Nyloc is a registered trade name of Forest Fasteners.

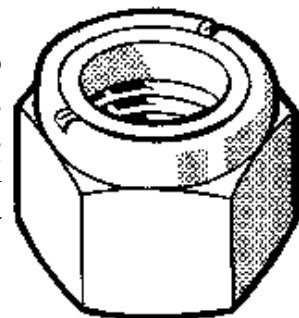

Nyloc Nut

OCTAGON HEAD

A bolt or screw whose head cross section is a regular polygon with 8 sides.

OVERTAPPING

Tapping of a thread following a plating operation so that the thread tolerances comply within specification allowing the internal and external threads to assemble. It is normal practice to overtap the internal rather than the external thread.

PILES

Term used in structural engineering for the joint plates.

PITCH

The nominal distance between two adjacent thread roots or crests.

PLY

A single thickness of steel forming part of a structural joint.

POOCHING

Pooching is a term sometimes used to describe the effect of the area immediately surrounding a tapped hole being raised up as a result of the tension from the stud. Tapped holes are often bored out for the first couple of threads to eliminate this problem.

PRELOAD

The tension created in a fastener when first tightened. Reduces after a period of time due to embedding and other factors.

PREVAILING TORQUE

The torque required to run a nut down a thread on certain types of nuts designed to resist vibration loosening. The resistance can be provided by a plastic insert or a noncircular head.

PROOF LOAD

The proof load of a nut is the axially applied load the nut must withstand without thread stripping or rupture. The proof load of a bolt, screw or stud is the specified load the product must withstand without permanent set.

PROPERTY CLASS

A designation system which defines the strength of a bolt or nut. For metric fasteners, property classes are designated by numbers where increasing numbers generally represent increasing tensile strengths. The designation symbol for bolts consists of two parts:

1. The first numeral of a two digit symbol or the first two numerals of a three digit symbol approximates 1/100 of the minimum tensile strength in MPa.
2. The last numeral approximates 1/10 of the ratio expressed as a percentage between minimum yield stress and minimum tensile stress.

Hence a fastener with a property class of 8.8 has a minimum tensile strength of 800 MPa and a yield stress of $0.8 \times 800 = 640$ MPa.

The designation system for metric nuts is a single or double digit symbol. The numerals approximate 1/100 of the minimum tensile strength in MPa. For example a nut of property class 8 has a minimum tensile strength of 800 MPa. A bolt or screw of a particular property class should be assembled with the equivalent or higher property class of nut to ensure that thread stripping does not occur.

PRYING

The amplification of an external force acting on a bolt by a lever action which can occur when that force is an eccentric tensile load.

REDUCED SHANK BOLT

A bolt whose shank diameter is smaller than the nominal diameter of the bolt (normally the shank diameter of such a bolt is approximately equal to the effective diameter of the thread).

RELAXATION

The loss of clamping force in a bolt which commonly occurs as a result of embedment. Can also be caused by gasket creep, differential temperature expansion or vibration loosening.

RIGHTHAND THREAD

A screw thread that is screwed in by rotating clockwise. The majority of screw threads are right handed.

ROLLED THREAD

A thread formed by plastically deforming a blank rather than by cutting. The majority of standard fasteners have their threads formed by rolling. Most threads are rolled before any heat treatment operation. Significant improvements in fatigue life can be achieved by rolling the thread after heat treatment, this improvement is due to compressive stresses being induced in the roots of the thread. However, because of the increased hardness of the bolt blank, the die life can be significantly reduced. Rolling the thread also generally improves the surface finish which can have a beneficial effect on fatigue life.

ROOT DIAMETER

Identical to MINOR DIAMETER

SCREW

A headed threaded fastener that is designed to be used in conjunction with a pre formed internal thread or alternatively forming its own thread. Historically, it was a threaded fastener with the thread running up to the head of the fastener that has no plain shank. However this definition has largely been superseded to avoid confusion over the difference between a bolt and a screw.

SCREW THREAD

A ridge of constant section which is manufactured so that a helix is developed on the internal or external surface of a cylinder.

SEMS

A screw and washer assembly. A screw or bolt which has a captive washer. The washer is frequently loose on the plain shank of the fastener, the shank diameter being equal to the effective diameter of the thread; the thread being rolled from this diameter. The origin of the word is a frequent question. In the 1930's E. C. Crowther was a representative for a company that sold both shakeproof washers and screws. He came up with the idea of placing the washer on the screw before it was thread rolled. The major diameter of the screw being larger than the washer hole prevents it from coming off. The Illinois Tool Works made machines that produced these patented pre-assembled washers and screws. The s at the end of SEMs is thought to have been subsequently picked up because they are not usually purchased individually. In spite of the original patents and trademarks the word SEMS is generally recognised as a generic term applicable to screw and washer assemblies.

SET SCREW

A set screw is a threaded fastener that is typically used to hold a sleeve, collar or gear on a shaft to prevent relative motion. It is a threaded member that normally does not have a head. Unlike most other threaded fasteners it is basically a compression device normally used to generate axial thrust. Various socket types are provided to allow the set screw to be rotated. These types include hexagon socket, fluted socket, screwdriver slot and square head. Various point designs are available (the part of the set screw that rotates against the shaft being secured) and include:

Cup - Hollowed end, is the most commonly used point style. Used when the digging in of the point is not undesirable.

Cone - Pointed end, this type generates the highest torsional holding power and is typically used for a permanent connection.

Oval - Rounded end that is typically used when frequent adjustment is required.

The oval end prevents/reduces indentation.

Flat - Cause little damage to the shaft and are used when frequent adjustment is required.

Dog - Flat end with the threads stopping short of the end with the end fitting into a hole.

SHANK

That portion of a bolt between the head and the threaded portion.

SHOULDER SCREWS

A threaded fastener with a plain, precision machined, shank that is used for location purposes. They are typically used for pulleys and linkages.

SKIDMORE BOLT TENSION CALIBRATOR

The Skidmore-Wilhelm bolt tension calibrator is a hydraulic load cell used to determine the tension in a bolt or other threaded fastener. The tension in the bolt compresses fluid in a hydraulic cylinder, a pressure gauge connected to the cylinder is then calibrated to read in terms of force rather than pressure.

SNUG TORQUE

The torque required to pull plates together so that direct contact occurs; often used in angle control tightening. The snug torque ensures that metal to metal contact occurs at all the interfaces within the joint. It is only at this point that the required angle of rotation start in order that the bolt is tightened sufficiently. The snug torque is usually determined experimentally on the actual joint.

SNUGGING

The process of pulling parts of a joint together, most of the input turn during this process is absorbed in the joint with little tension being given to the bolt.

SOCKET HEAD CAP SCREW

A screw with a round head, usually with a hexagon indentation in the head for tightening purposes. Used on machine parts and is typically made from high strength steel (grade 12.9 in metric).

SOFT JOINT

A joint in which the plates and material between the nut and bolt bearing surfaces have a low stiffness when subjected to compression by the bolt load. In such a joint, the bolt (or nut) typically has to be tightened by two or more complete turns, after it has been torqued to the snug condition, before the full tightening torque is achieved. Often the placement of a gasket in a joint results in a soft joint.

SOFT TORQUE

An alternative name, used by some manufacturers, for snug torque.

STATIC FRICTION

Friction at rest; a force is required to initiate relative movement between two bodies - static friction is the force that resists such relative movement. Sometimes referred to as stiction.

STEP-LOCK BOLT (SLB)

The Step-Lock Bolt (SLB) is a thread form that has been modified to resist vibration loosening. The thread has several horizontal portions (i.e. no lead angle) whose purpose is to prevent torsion being developed in the bolt as a result of the loosening purpose. It is these horizontal portions that are known as steps. Published literature indicates that the thread form performs well when tested on a transverse vibration test machine. However manufacturing difficulties may prevent its widespread adoption.

STIFFNUT

A term used to describe a lock nut which has a prevailing torque.

STRENGTH GRADE

See PROPERTY CLASS

STRESS AREA

The effective cross sectional area of a thread when subjected to a tensile force. It is based upon a diameter which is the mean of the pitch (or effective) and the minor (or root) diameters of the thread. The use of this diameter stems from the work of E. M. Slaughter in the 1930's. He completed carefully controlled tests using various sizes of standard threads and compared their strength with machined bars made from the same bar of material. He found that this mean diameter gave results that agreed with the tensile test results to within about 3%. The error on the minor and pitch diameters was about 15%. Tests completed subsequent to these by other investigators have also shown that the stress diameter is a reasonable approximation to a thread's tensile strength. (Referance: 'Tests on Thread Sections Show Exact Strengthening Effect of Threads.' by E. M. Slaughter, Metal Progress, vol 23, March 1933 pp. 18-20)

STRUCTURAL BOLT

A structural bolt is a heavy hexagon head bolt having a controlled thread length intended for use in structural connections and assembly of such structures as buildings and bridges. The controlled thread length is to enable the thread to stop before the joint ply interface to improve the fastener's direct shear performance. This term is used in civil and structural engineering but is not frequently used in mechanical engineering.

STUD

A fastener which is threaded at both ends with an unthreaded shank in between. One end (which often has a thread tolerance which results in more thread interference) is secured into a tapped hole, the other is used with a nut.

SYMMETRICAL THREAD

A symmetrical thread is one which has both flanks of the thread profile inclined at the same angle.

TAYLOR-FORGE METHOD

A method developed by four engineers of the Taylor-Forge Company in Chicago in the 1930's that subsequently formed the basis of the ASME code for flanged joint design. The assumptions made by the method are now generally regarded as too simplistic. This method gives rise to the m and y gasket factors.

TENSION WASHERS

A general name given to spring washers, curved washers, Belleville washers and disc springs. This type of washer provides a relatively low stiffness (compared to the joint stiffness) and can be used to act as a spring take-up with a bolt to prevent movement between parts.

THREAD CREST

The top part of the thread. For external threads, the crest is the region of the thread which is on its outer surface, for internal threads it is the region which forms the inner diameter.

THREAD FLANK

The thread flanks join the thread roots to the crest.

THREAD HEIGHT

This is the distance between the minor and major diameters of the thread measured radially.

THREAD LENGTH

Length the portion of the fastener with threads.

THREAD ROOT

The thread root is the bottom of the thread, on external threads the roots are usually rounded so that fatigue performance is improved.

THREAD RUNOUT

The portion at the end of a threaded shank which is not cut or rolled to full depth, but which provides a transition between full depth threads and the fastener shank or head.

THREADLOCKER

Can be a term used for a number of vibration resistant products but is now usually reserved for threadlocking adhesives. Specifically, a liquid anaerobic adhesive applied to nut or bolt thread, once hardened it fills the inner spaces between the threads to produce a solid plastic of a known shear strength.

TIN/ZINC ALLOY ELECTROPLATING

Tin/zinc alloy coatings (typically 70% tin and 30% zinc) are applied to threaded fasteners to provide a corrosion resistant coating. One of the advantages of such coatings is that bimetallic corrosion will not occur when placed into contact with such metals as aluminium or steel.

TOLERANCE CLASS

A combination of tolerance grade and a fundamental deviation which is given to an internal or external thread. A tolerance class for an internal thread when combined with the tolerance class for an external thread gives the class of fit for the mating threads.

TOLERANCE GRADE

The difference between maximum and minimum metal conditions for a tolerance applied to a screw thread. For metric threads the tolerance grade is given a number.

TORQUE MULTIPLIER

A gearbox used to increase the torque produced by a small hand wrench.

TORQUE WRENCH

A manual wrench which incorporates a gauge or other method to indicate the amount of torque transferred to the nut or bolt.

TURN OF THE NUT METHOD

See [ANGLE CONTROLLED TIGHTENING](#)

U BOLT

A U shaped fastener threaded at both ends used primarily in suspension and related areas of vehicles.

ULTRASONIC EXTENSOMETER

An instrument which can measure the change in length of a fastener ultrasonically as the fastener is tightened (or measure the length before and after it is tightened).

VIRTUAL EFFECTIVE DIAMETER

The effective diameter of a thread but allowing for errors in pitch and flank angles.

WAISTED SHANK BOLT

A bolt whose diameter is less than the minor diameter of the thread. Frequently the shank of the bolt is 0.9 times the root diameter.

WIRE THREAD INSERT

A threaded insert that is typically used for tapped hole repair or to improve the thread stripping strength of softer metals such as zinc and aluminium. The inserts are assembled into a previously tapped hole using a special driving tool. A thread locking compound is frequently used to secure the insert if the assembly is subject to vibration.

YIELD CONTROLLED TIGHTENING

A fastener tightening method which allows a fastener to be tightened to yield. The angle of rotation of the fastener is measured relative to the applied torque, yield being assessed when the slope of the relationship changes to below a certain value. Sometimes called joint controlled tightening.

ZINC ELECTROPLATING

Zinc electroplating is a common way to protect threaded fasteners from the effects of corrosion. Zinc electroplating can be completed in acid chloride, alkaline or cyanide baths. Supplemental coatings are frequently applied to zinc electroplating. These coatings, such as zinc phosphate or chromate conversion, provide a protective passivation layer on the zinc which assists in reducing the corrosion rate.

ZINC/COBALT ALLOY ELECTROPLATING

This coating is similar to zinc electroplating completed in an acid chloride bath - a small amount of cobalt (typically about 1%) is added to increase the plating speed.

ZINC PHOSPHATE CONVERSION COATING

A zinc phosphate conversion coating is frequently added to zinc electroplated parts, such as bolt threads, to improve corrosion resistance. This type of chemical conversion coating provides a protective passivation layer on the zinc improving its corrosion resistance.